

This booklet is for use with Contender Pistols equipped with  
**THE EXTERNAL MANUAL FIRING PIN SELECTOR\***

\*Contender Pistols manufactured after April 1, 1984, and older Contender models which have been converted to this new hammer style.

This booklet contains information that is essential to the safe use and maintenance of the Contender Pistol. **You must read this material in its entirety and fully understand its significance before you can safely use this firearm.** If a Contender is loaned or sold (by an individual or dealer) this booklet must accompany the pistol. Replacement booklets are available at no charge from our factory.



*Important Instructions on the USE and CARE  
of the*

**CONTENDER<sup>®</sup>**

THOMPSON/CENTER ARMS • P.O. BOX 5002, FARMINGTON RD., ROCHESTER, NH 03866

## Table of Contents

General Rules for Safe Use and Handling of the Contender® Pistol	Page 1- 3
External Manual Firing Pin Selector	Page 4
Opening, Simulated Loading & Closing the Contender® Action	Page 5- 7
Carrying and Firing Your Contender® Pistol	Page 7-10
Changing Barrels	Page 11
Trigger Adjustment	Page 11-12
Sight Adjustment	Page 12-13
Detachable Chokes	Page 13
Lubrication	Page 13
Barrel Obstructions	Page 14
Failure to Fire	Page 14
Service	Page 14
Statement of Liability	Page 15
Lifetime Warranty	Page 15
Unsafe Arms and Ammunition Combinations	Page 16
Parts List	Page 17-19

CONTENDER® is a registered trademark  
of Thompson/Center Arms Co.

# KNOW YOUR FIREARM BEFORE YOU ATTEMPT TO USE IT!

**Designed as a Hunting/Sports Pistol, the Contender is uniquely different from other handguns.** Its single shot, break open action is relatively simple to understand and safe when the required ingredients of "common sense" and "safe gun handling" are applied to its use and care.

**However, do not assume that a familiarity with other firearms has equipped you with a knowledge of "safe gun handling" as these words now apply to your new Contender.** Each gun design is different from another and each functions accordingly.

All machines, be they chain saws, automobiles, lawnmowers or firearms are built to function as **mindless mechanical slaves. They serve only as well as your intellect dictates.** Carefully used, your chain saw will cut up a winter's supply of firewood. Carelessly used, your chain saw will cut other things with able willingness. A firearm is no different—it is equally nonselective as to target or purpose.

Inasmuch as the responsibility for the use of a firearm rests with its user, you must understand the mechanics before you can shoulder the responsibility for its use. That is what this booklet is all about.

**YOU MUST READ THIS MATERIAL  
BEFORE USING THE CONTENDER.®**

# GENERAL RULES FOR SAFE USE AND HANDLING OF THE CONTENDER® PISTOL

- 1 If you are unfamiliar with firearms seek professional instruction.** Qualified organizations such as local gun clubs, the National Rifle Association and State Hunter Safety programs offer courses which teach safe gun handling and proper hunting procedures. Those who are unfamiliar with firearms should seek guidance from an instructor who is qualified by one of these organizations.
- 2 Always point the muzzle of your Contender downrange.** The possibility of accidental discharge is a constant danger when using a firearm. If the muzzle is pointed downrange, away from yourself, other people, domestic animals or property, then there can be no injury or damage from an accidental discharge.
- 3 Never load your Contender until you are ready to fire it.** If your Contender is not loaded until you are ready to fire and are directing your full concentration to it and the target then there can

be no accidental discharge of the pistol. Never transport or carry a loaded Contender in a vehicle. Never hand a loaded Contender to another person. Never store a loaded Contender in your home. Never cross a fence, climb a tree, jump a ditch or engage in any activity which distracts your attention while holding or carrying a loaded Contender. Never attempt to clean a loaded Contender. Carelessness in observing any of these rules can result in an accidental discharge which can cause injury or death to yourself or others.

- 4 Be physically fit and mentally alert when using your Contender.** The use of your Contender involves forceful physical actions which require strength and concentration. Never use alcoholic beverages or drugs before shooting or handling

GENERAL RULES FOR SAFE USE AND HANDLING  
OF THE CONTENDER CONTINUED ON PAGE 2.

your Contender. Never use your Contender when you are overly tired. If you use medication or have medical implants consult your physician before using your Contender.

**5 Know the condition of your Contender before firing.** Be sure the pistol is loaded with ammunition of the proper caliber. Be sure the breech is securely locked. Be sure the barrel is clear of obstructions (including excess oil, mud, dirt, snow or any foreign material). Failure to observe this rule may result in damage to the gun and injury to the shooter or bystanders.

**6 Be sure of your target.** Never fire your Contender unless there is a back stop behind your target. Never fire your Contender in the field unless you have a clear view of your target. Never fire at a noise or movement in the brush. If hunting with others always know where other members of your party are located. Never fire your Contender if there is a possibility that a member of your hunting party is down range. Never shoot at flat, hard surfaces such as rocks or water. A bullet may ricochet off these surfaces causing injury or death.

**7 Respect the Contender.** Used properly, your Contender will give you years of pleasure. Used improperly, carelessly or abused, your Contender is a dangerous instrument and is capable of causing serious injury, death or property damage. Always treat your Contender as if it were loaded. Do not drop your Contender or allow it to be struck a blow. Dropping or striking may cause movement of internal parts in such a manner as to cause an accidental discharge.

**8 Protect your eyes and ears when firing your Contender.** Always wear shooting glasses to protect your eyesight from air borne particles and ear protectors to guard against hearing loss due to loud noise when firing your Contender.

## AMMUNITION

### STANDARD FACTORY LOADED CARTRIDGES

Contender design provides for the use of interchangeable barrels which are chambered for a variety of factory loaded cartridges. The proper cartridge for each

**GENERAL RULES FOR SAFE USE AND HANDLING  
OF THE CONTENDER CONTINUED ON PAGE 3.**

barrel is clearly marked by its standard industry designation on the top left side of each barrel. Barrels chambered for standard cartridges should be used with high quality commercially manufactured ammunition with a packaging and head stamp designation that corresponds exactly to the barrel marking. **If you have any questions concerning the proper ammunition for your Contender Pistol, write or call our factory. Do not fire the pistol!**

### **CUSTOM (WILDCAT) CARTRIDGES**

Several Contender barrels are available in custom cartridge chambering for those qualified people who are totally experienced in reloading procedure. The novice should not attempt to use these cartridges until he or she has developed the required background and knowledge.

Handload custom ammunition only in accordance with the standards and guidelines set by component and reloading tool manufacturers. These companies publish reloading manuals which must be read, understood and adhered to. Use only that data which is published by a reliable source and thoroughly tested by the component or tool manufacturer. Never exceed the loads listed for a particular powder, bullet and case combination and never substitute components for

those listed. When using listed data, bear in mind that production changes affecting ballistic performance can occur at any time and without our knowledge. If there is ever a question as to the correctness of a component, write to its manufacturer. Failure to follow proper procedure can result in serious injury and/or death to yourself or others.

If you are unable to obtain reliable information with respect to procedure or standards for reloading, contact our customer service department for assistance. See address on front cover.

### *Custom Alterations & Conversions*

Contender Pistols or Contender accessory barrels which are subjected to custom alteration or conversion other than those performed by the Thompson/Center Custom Shop are not covered by our warranty. **Thompson/Center does not endorse or recommend any type of custom alteration other than those performed by the Thompson/Center Custom Shop.** Responsibility for other conversions rests solely with the gunsmith performing the conversion. If the work is done improperly or without proper judgement the firearm can rupture or malfunction causing injury or death to the shooter or bystanders.

# Your Contender® Pistol is Equipped with an **EXTERNAL MANUAL FIRING PIN SELECTOR**

Your Contender Pistol is designed with **two firing pins** which accommodates either Rim or Center Fire cartridges and allows for the interchangeability of Contender barrels. These firing pins are located in the Receiver Bridge forward of the hammer. The upper firing pin is used for Rim Fire cartridges while the lower pin is used for Center Fire cartridges.

**THE EXTERNAL MANUAL FIRING PIN SELECTOR** is located on the top of the hammer (see Photos 1, 2 & 3 on right). The selector activates the unique rim and center fire optional ignition systems. When the selector is moved to **Position 1** a hammer nose aligns with the rim fire (top) firing pin and readies it for firing. **Position 2 is a safety position.** When the selector is moved to **Position 3** a hammer nose aligns with the center fire (bottom) firing pin and readies it for firing. **Note that when the selector is in Position 1 or Position 3 the red dot is exposed indicating that the firing pins are armed and that the pistol will discharge if the hammer falls with a round in the chamber.**

Study the three photos on the right and commit them to memory. Bear in mind that **only Position 2 is the safety position.** The following text and photos will instruct on the proper use of the External Manual Firing Pin Selector.



**THIS EXTERNAL MANUAL FIRING PIN SELECTOR ACTIVATES THE RIM AND CENTER FIRE OPTIONAL IGNITION SYSTEM. POSITION 2 IS A SAFETY POSITION.**

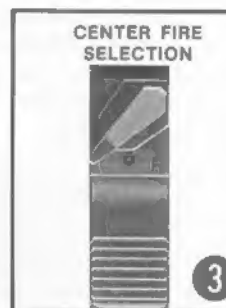
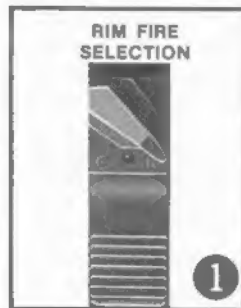

**AFTER YOU HAVE OPENED THE ACTION (AS EXPLAINED ON PAGES 5 & 6) YOU MUST SET THE EXTERNAL MANUAL FIRING PIN SELECTOR ON SAFETY POSITION 2!**

# Never Load or Attempt to Use The Contender® Until You Become Completely Familiar With Its Operation!

## ▶ OPENING, SIMULATED LOADING & CLOSING THE CONTENDER ACTION

Hold the pistol at its balance point as pictured in Photo A. Bear in mind that the Contender is a hunting and target handgun designed for sporting use only. Its proper operation requires the same "two handed" care that would normally be given a quality break open type shotgun. **By design, the Contender Pistol has no importance as a combat weapon. Such applications as fast drawing, speed shooting, one handed loading or "snap shooting" are dangerous and should never be attempted with a Contender!** It is just not that kind of a handgun. The only proper application for a Contender is hunting, target or sport shooting, so consequently its user has all the time in the world to operate this firearm correctly and safely.

Use the trigger finger of your (right or left) hand to

open the action. Place the finger low on the "spur" to obtain maximum leverage and give it a **fast sharp pull** as shown in Photo B. Pull this spur to the rear and upwards at the same time.





As the action opens, exposing the chamber, a full series of mechanical events take place. It is necessary for you to understand and to appreciate the significance of these moving parts if you are to use your Contender correctly.

**AT THIS POINT SET YOUR EXTERNAL MANUAL FIRING PIN SELECTOR ON SAFETY POSITION 2 (SEE PHOTO 2, PAGE 4).**

**THE SEQUENCE OF MECHANICAL EVENTS PICTURED ARE IMPORTANT TO THE PROPER FUNCTIONING OF THIS FIREARM. INASMUCH AS THEY ARE ACCOMPLISHED BY A DIRECT AND POSITIVE PULL ON THE "SPUR", YOU MUST ALLOW THE TRIGGER GUARD TO EXPERIENCE FULL TRAVEL TO ITS POSITIVE STOP POSITION!**

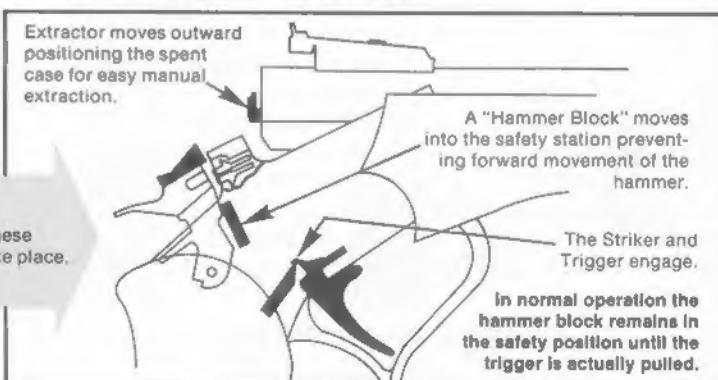



At this point you would normally load the firearm, so let's assume that you have done so. **DON'T LOAD AND FIRE YOUR CONTENDER UNTIL YOU HAVE READ THROUGH THIS BOOKLET.** When actually loading the pistol, the barrel is tilted slightly downward and a cartridge is inserted into the chamber in the conventional manner. The cartridge is pushed forward until its head contacts the extractor. Photo D shows the proper method of closing the action. If the action does not close smoothly, do not force it closed on a live round. Remove the live round from the chamber and inspect the cartridge and chamber.



If you are unable to recognize and correct the problem, have the pistol examined by a qualified gunsmith. Forcing the action closed on a live round may cause accidental discharge. An accidental discharge may cause injury or death.

## ▶ CARRYING AND FIRING YOUR CONTENDER® PISTOL

The Contender design does not employ a half cock notch and it is extremely important that the user understand this fully. If, after reading this booklet, you still have questions write or call our customer service department (see page 15 for address).



The Contender is equipped with **two safety devices** which function independently of each other (1. **Safety position on the External Manual Firing Pin Selector.** 2. **Internal Hammer Block**). When the Contender action is broken open properly, as explained on pages 5 and 6, the hammer block moves up into a position between the hammer and the frame. In this position the hammer cannot move forward.

Study the illustration on Page 7. Note that when the hammer block is in the up position there is a visible space between the face of the hammer and the firing pins. Equally, when the External Manual Firing Pin Selector is set in safety position 2 (as it should be), both hammer noses (Rim Fire and Center Fire) are out of alignment with the firing pins.

The hammer block will remain in the up (safety) position until trigger-striker engagement is released (Note: see caution on Page 9 regarding the Contender receiving a sharp blow; see caution on Page 10 regarding improper operation of the trigger guard; see caution on Pages 11 and 12 regarding trigger adjustment). **The Contender Pistol should never be carried or holstered in a cocked position. The hammer should be drawn to full cock and the External Manual Firing Pin Selector moved to a fire position (position 1 or 3) only when you are ready to fire. Your finger or fingers should not be in contact with the trigger except during the act of firing.**

## FIRING THE CONTENDER!

The hammer is drawn to cocked position and the External Manual Firing Pin Selector set to an armed position (position 1 or 3) only during the act of firing. When you are ready to fire, support the pistol with two hands (as pictured in Photo E). Keep the muzzle down range. Draw the hammer to full cock position. Set the External Manual Firing Pin Selector to the fire position required for your cartridge (Rim or Center Fire). Aim carefully at the target and fire the shot!

### **E** FIRING!

Never cock the hammer until the instant before firing. Support the pistol with two hands as you move the External Manual Firing Pin Selector into armed position.



**NOTE:** Illustration shows Center Fire selection. If you are using a Rim Fire cartridge, see insert on right.

After the shot is fired, open the action, remove the fired round **AND IMMEDIATELY RESET THE EXTERNAL FIRING PIN SELECTOR TO SAFETY POSITION 2.** At all times except for the instant before and after firing this selector must be set in safety position 2 **NEVER CLOSE THE ACTION ON A LOADED ROUND UNTIL YOU HAVE CHECKED AND ASSURED YOURSELF THAT THIS SELECTOR IS SET IN ITS SAFETY (UNARMED) POSITION.**

**The safeties on the Contender are mechanical devices and are not foolproof. They are intended to be used in combination with common sense and safe gun handling practices.** Do not rely on the safeties to overcome the danger of injury to yourself or others from careless handling or abuse of your Contender.

**DO NOT LOAD THE CONTENDER UNTIL YOU ARE READY TO FIRE IT.** Always keep the muzzle of your Contender pointed down range.

If the Contender is dropped or struck a hard blow, the following steps should be taken. The action should be opened, the gun should be unloaded, the bore should be checked for obstructions, the action should be functioned to be sure that both safeties work properly; that the trigger adjustment is proper (see pages 11 and 12), that the hammer functions normally, and that there are no broken or deformed parts. If any problem or malfunction is noted the gun should be returned to the factory for service (see page 14).

**Should you decide NOT TO FIRE the Contender after the hammer has been FULLY COCKED, then you must take the following steps!**

If, after cocking the pistol, the shooter decides not to fire, one of the following sets of procedures must be followed.

1. Set the External Manual Firing Pin Selector on

safety position 2. Then, with the thumb on the hammer, pull up on the trigger guard spur until the action breaks open. This will release the hammer (allowing it to move forward) while keeping the hammer block engaged.

2. Set the External Manual Firing Pin Selector on safety position 2. Hold your thumb on the hammer and pull the trigger. **DO NOT ALLOW THE HAMMER TO DROP FREELY OR YOU MAY DAMAGE THE FIREARM.** Ease the hammer down slowly until it rests on the selector lever. Next pull up on the trigger guard spur until the action breaks open to reengage the internal hammer block safety.

**Whenever the hammer is cocked and then returned to uncocked position it is necessary to first set the External Manual Firing Pin Selector on safety position 2 and then perform one of the above set of procedures. If this manual operation is not performed, the internal hammer block safety will not be engaged. If a loaded Contender with firing pins armed is dropped or struck a blow without the internal hammer block safety engaged, it may discharge causing injury or death. Also the striker and trigger will not engage and you will be unable to cock the hammer for the next firing.** See photo "C" plus line drawing and explanation on page 6.

Bear in mind that the trigger guard spur acts as a lever to lock and to unlock the action. Consequently it must be free. **AT NO TIME SHOULD THE SHOOTER HAVE FINGERS AROUND THE**

**TRIGGER GUARD OR HAVE IT RESTING ON ANY SURFACE WHILE FIRING.**

Do not "dry fire" the Contender by pulling back the hammer and allowing it to drop. To do so will damage the hammer mechanism and/or the standing breech.

**To safely "dry fire" the Contender Pistol, you need not cock the hammer.** With the chamber unloaded, simply open and close the action as explained previously. Leave the hammer in its uncocked position and squeeze the trigger. This will release the striker allowing you to experience the exact trigger pull that is present when firing. See "Trigger Adjustment" on pages 11 and 12.

**PRACTICE AND LEARN THE MECHANICS OF THIS FIREARM BEFORE YOU USE IT!**

The previous text and illustrations are intended to instruct the shooter in the safe use of the Contender Pistol. We recommend that you reread this material. With the **CHAMBER UNLOADED** practice each step carefully until you have completely committed these procedures to memory. Then, and only then, can you safely load and fire this handgun.

## CHANGING BARRELS

With the action closed, remove the forend screw and forend. Super "14" Models have two forend screws which must be removed. Open the action to relieve the tension on the hinge pin. Carefully tap out the hinge pin (in either direction). To replace the barrel, simply reverse the process. Be sure that the Contender is unloaded before disassembling or changing barrels in order to prevent accidental discharge which may cause injury or death. Use barrels of Thompson/Center manufacture only which are marked with the cartridge designation and our company name.

## TRIGGER ADJUSTMENT

As an aid to the maintenance of a high level of performance the Contender is equipped with two trigger adjustment screws.

### 1 TRIGGER ENGAGEMENT SCREW

The Contender trigger can be adjusted for let-off travel (movement backward and forward). This adjustment screw (#36-3) is located at the top forward section of the trigger. Turning the adjustment screw clockwise will decrease the engagement and shorten the let-off travel. Turning the screw counterclockwise will increase the engagement and lengthen the let-off travel. All triggers are factory adjusted before shipment. They are set to what we feel is an optimum safe let-off travel. If additional adjustment is required it should be made with discretion.

**CAUTION: Too light of an adjustment can cause premature firing which may result in injury or death to the shooter or bystanders.** In order to check the adjustment for let-off travel the following procedure should be used. Cock the Contender with the chamber unloaded and the action open. Close the action "sharply". Repeat the procedure several times. If the hammer fails at all when the action is closed "sharply" the adjustment is too light. This condition must be corrected by turning the adjustment screw counterclockwise to increase the trigger engagement. This procedure should be performed after each and every adjustment of the trigger engagement.

## TRIGGER ADJUSTMENT (Continued)

If proper engagement cannot be obtained by using the adjustment screw, the Contender receiver should be returned to the factory for repair or replacement under our warranty program.

### 2. TRIGGER STOP SCREW

A trigger stop screw is located in the trigger guard directly behind the trigger. Extremely helpful for target shooting, this adjustment should be set on minimum. In other words, turn the adjustment until the trigger will not release, then gradually back off the adjustment until the trigger just releases. An extra quarter turn affords the proper setting and insures that the trigger will release every time.

**CAUTION: Too Light A Trigger Pull.** CONTENDER TRIGGERS ARE FACTORY SET TO WHAT WE CONSIDER TO BE AN OPTIMUM SAFE PULL. ALTERATION OF THE TRIGGER SPRING OR USE OF A NON-FACTORY SPRING CAN CREATE A DANGEROUSLY LIGHT TRIGGER PULL. TOO LIGHT A TRIGGER PULL CAN CAUSE PREMATURE FIRING WHICH MAY INJURE THE SHOOTER OR A BYSTANDER.

Altered parts may also produce an unsafe trigger pull. If trigger pull on a Contender is found to be too heavy (greater than 4 lbs. pull) or rough, the receiver should be returned to the factory for repair or replacement under our warranty program. In no event should parts be filed, ground, honed or replaced by non-factory parts.

## SIGHT ADJUSTMENT

Your Contender has been targeted before shipment, however, some additional sight adjustment may be necessary to compensate for individual holding, etc.

To guard against accidental discharge which may cause injury or death, be sure that the Contender is unloaded and that the action is open when performing this operation.

## SIGHT ADJUSTMENT (Continued)

**ALL BARRELS WITH ADJUSTABLE SIGHTS:** On these models all windage and elevation adjustments are made on the rear sight only. Elevate (turn counterclockwise) the top screw to compensate for a low group or reverse the procedure to compensate for a high group. Turning the windage screw counterclockwise moves the point of impact to the left. Turning the windage adjustment clockwise moves your group to the right.

## DETACHABLE CHOKE MODELS

Internal choke Contender Models were available in .357 or .44 Magnum (discontinued) for use with Hot Shot Cartridges. Current internal choke models are offered in .45 Colt/ .410 ga. allowing the use of the standard .410 gauge 3" shotshell. **IN ALL INSTANCES THE CHOKE MUST BE REMOVED WHEN STANDARD BALL AMMUNITION, RIFLED SLUGS OR BUCKSHOT OF THE APPROPRIATE CALIBER IS TO BE USED.**

After heavy use of shot cartridges, clean the barrel and choke with a tight fitting stiff wire brush to remove any accumulation of lead. To guard against accidental discharge which may cause injury or death, be sure that the Contender is unloaded and that the action is open when performing this operation.

## LUBRICATION

To guard against accidental discharge which may cause injury or death, be sure that the Contender is unloaded and that the action is open when performing this operation.

Guard against malfunction and sludge build-up by using only dry lubricant such as graphite on the internal parts. Never use any oils or grease on any internal parts. Use gun oil or light machine oil to protect the outside surface.

## BARREL OBSTRUCTIONS

Before loading the Contender check the bore to insure that it is free of obstructions (cleaning patches, excess oil, mud, snow or other foreign materials). If the firearm is dropped it should be unloaded and inspected to insure that the bore has not become clogged with dirt, snow, twigs or other foreign material.

If, when firing (particularly reloads), the report is weak or peculiar, stop immediately. **Inspect the barrel for a stuck bullet.** If the bore is obstructed, return the barrel to the factory. **Do not continue to fire the pistol.**

---

## FAILURE TO FIRE

If the Contender fails to fire, keep the gun pointed at the target or in a safe direction for at least 30 seconds. If the Contender does not fire after 30 seconds, carefully open the action. Check the External Manual Firing Pin Selector to insure that it was in the proper position for firing. Extract and examine the cartridge. If primer on the cartridge is indented, it should be disposed of in accordance with ammunition manufacturer's instructions for faulty ammunition or in any other safe manner. If primer on the cartridge is not indented or only slightly indented, then your Contender should be examined by a qualified gunsmith or returned to the factory for service under our warranty program.

---

## SERVICE

Tel: 603-332-2441

Should your handgun require adjustment, repair or refinishing, we strongly recommend that the pistol be returned to the factory. There is no other way to ensure that the work will be done by a competent staff or trained technicians.

Pistols returned to the factory should be **marked for the attention of the service department.** A letter of instructions should be enclosed with the gun. Adherence to these suggestions will prevent loss of time and facilitate handling at the factory.

Our service department will give your pistol a complete inspection. They will evaluate the problem or problems specified in your covering letter. If the work required is not covered by our 'Lifetime Warranty' (see Page 15) you will receive a **quotation which must be authorized by you.** No actual work will be done without your approval.

Ship complete pistols or receivers U.P.S. Barrels only may be sent parcel post or U.P.S.



## STATEMENT OF LIABILITY

This gun is classified as a **FIREARM OR DANGEROUS WEAPON** and is surrendered by us with the express understanding that we assume no liability for its resale or safe handling under local laws and regulations. Thompson/Center Arms assumes no responsibility for physical injury or property damage resulting from either intentional or accidental discharge, or for the function of any gun subject to influences beyond its control, and will honor no claims which may result from careless handling, unauthorized adjustments, defective or improper ammunition, corrosion or neglect.

For your protection, examine your gun carefully at the time of purchase. Fill out and mail the registration card promptly. Be certain that it bears the gun's serial number which you will find on the receiver.

Contender Pistols and Contender accessory barrels which are subjected to custom alteration or conversion other than those performed by the Thompson/Center Custom Shop are not covered by our warranty. **Thompson/Center does not endorse or recommend any type of custom alteration other than those performed by the Thompson/Center Custom Shop.** Responsibility for such conversions rests totally with the gunsmith performing the conversion. If the work is done improperly or without proper judgement the firearm can rupture or malfunction causing injury or death to the shooter or bystanders.

## LIMITED WARRANTY

THOMPSON/CENTER ARMS provides a warranty for all factory finished firearms for the LIFETIME OF THE ORIGINAL CONSUMER PURCHASER. Any such firearm or part thereof returned, postage paid, to the factory at Rochester, New Hampshire 03867, will be repaired or replaced to our commercial standards free of charge, and returned to the consumer purchaser postage prepaid. This warranty is established by return of our authorized warranty card which should be done within thirty (30) days of purchase. **This warranty does not cover any damage caused by custom alteration of the firearm!** Services performed by the Thompson/Center Custom Shop do not void the warranty. Thompson/Center Arms reserves the right to refuse to repair or replace firearms, or parts thereof, damaged by abuse or misuse. This Warranty gives you specific legal rights, and you may also have other rights which vary from State to State.

Address all correspondence and inquiries to: **THOMPSON/CENTER ARMS**  
P.O. Box 5002, Farmington Road, Rochester, New Hampshire 03866

**STATEMENT ISSUED BY  
SPORTING ARMS  
& AMMUNITION  
MANUFACTURERS  
INSTITUTE (SAAMI)  
UNSAFE ARMS AND  
AMMUNITION  
COMBINATIONS**

Ammunition used in a firearm must be the same caliber or gauge as that marked on the firearm by its manufacturer. If the firearm is not marked as to caliber or gauge, or if it appears that the original marking has been overprinted or changed, it is the responsibility of the gun user to have a qualified person determine what cartridge or shell can safely be used in the firearm.

The firing of a cartridge or shell other than that for which the firearm is chambered can result in the cartridge or shell rupturing and releasing high pressure gas that can damage or destroy the firearm and kill or seriously injure the shooter and persons nearby.

There are countless combinations of specific cartridges and firearm chambers which are unsafe. Many of these unsafe combinations are recognizable because of significant dimension differences between the cartridge and the firearm chamber. Dangerous combinations may also have similar chamber and cartridge dimensions. It is not possible to list every unsafe combination; therefore, in the interest of safety, use only the cartridge (or shell) designated by the firearm or ammunition manufacturer for use in a specific firearm. The cartridge caliber or shotshell gauge must be marked on the firearm frame, receiver or barrel by its manufacturer.

The practice of rechambering firearms is not guided by industry standards. It is possible that a firearm which has been rechambered may not be rechambered properly or the rechambered caliber may not be marked on the firearm. The firearm user is responsible to find out from a qualified person the cartridge caliber or shell gauge for which the firearm has been rechambered.

NUMBER	PART NAME
36-2	Trigger Stop Screw
23	Two Piece Bolt
65-2	Bolt Spring
099	Bolt Stop Pin
16	Bushing Screw
62	Dovetail Lock
12	Extractor (Specify Caliber)
86	Extractor Spring 222 Rem. 221 Fireball 30 Carbine, 9mm, 6mm TCU 35 Rem 45 Win. Mag, 223 Rem, 6.5mm TCU 7mm TCJ
69	Extractor Stop Pin
14	Firing Pin Bushing
15A	Firing P.n. Center Fire
15	Firing P.n. Rim Fire
26	Firing Pin Spring
7610	Forend Complete (Octagon)
7612	Forend Complete (Bul.)
7614	Forend Complete (Super 14)
7616	Forend Complete (Super 16)
96-2	Forend Screw 10" Rear Super 14 & Rear Super 16
32-1A	Forend Screw Front Super 14 & Super 16
33A	Forend Bushing 16"
33B	Forend Washer Contender
7507	Grip
60-2	Grip Cap
42-5	Grip Cap Screws (3)
35	Grip Screw
34	Grip Screw Lock Washer
38	Trigger Guard Stop Screw

NUMBER	PART NAME
38-A	Trigger Guard Lock Screw
24 6	Guard Stop Spring *See note below
632	Firing Pin Selector-Factory Installation Only
95	Hammer Nose Pin (2)-Factory Installation Only
52	Selector Detent Ball-Factory Installation Only
51	Selector Detent Spring Factory Installation Only
9186	Hammer Assembly Complete-Factory Installation Only
59	Hammer Pin
66	Hammer Spring
18	Hinge Pin
58	Roller
8-1	Safety
48-0	Safety Spring
173	Sear *See note below
20	Sear Pin
25	Sear Spring
56	Sear Plunger
202	Front Sight Ramp 10 & 14" Barrel
202A	Front Sight Ramp 16" Barrel
200	Front Sight Blade (Specify Cal. and Bbl Length)
200A	Front Sight Blade 16" Specify Caliber
206	Front Sight Blade Pin
201	Front Sight Screw Rear
202 5	Front Sight Screw, Front
200 5	Front Sight Complete (Specify Cal. 10" & 14" Bbl)
200 5A	Front Sight Complete 16" Bbl. (Specify Caliber)
75-0	Rear Sight Base
41-A	Rear Sight Mounting Screw
91	Rear Sight Spiral Pivot Pin

112	Rear Sight Elevation Spring
108-8	Rear Sight Elevation Screw
3	Rear Sight Detent Ball
9191-1	Rear Sight Blade Sub Assy W/Low Blade 145"
9191-2	Rear Sight Blade Sub Assy W/Med Blade 230"
9191-3	Rear Sight Blade Sub Assy W/High Blade 330"
9191 A	Rear Sight Complete (Specify Cal. & Bbl Length)
84 1	Striker
22 3	Striker Pin *See note below
85	Striker Spring
120-5	Trigger *See note below
36-3	Trigger Tension Screw *See note below
70-1	Trigger Guard *See note below
18 3	Trigger Guard Pivot Pin *See note below
18-5	Trigger Guard Pivot Pin Clip *See note below
7 5	Trigger Pin *See note below
172-1	Trigger Plunger *See note below
43-0	Trigger Spring *See note below
88B	Interlock Screw
9184	Trigger Guard Assembly *See note below
89 1	Inter-Lock Safety
73	Inter-Lock Safety Spring
10	Barrel Assembly Complete See Catalog
9175	Internal Choke Tube 45/410
9181	Choke Wrench 44 - 45 Cal. & 45/410
10	Barrel Assy complete See Catalog

**NOTE** Parts followed by an asterisk are for current production Contender Pistols only which incorporate the new 'Easy Open' design feature. **These parts will fit Contender Pistols with serial numbers of 195,000 or higher.** For early model Contender Pistols (serial numbers lower than 195,000) use the same part numbers but indicate "Old Model" on your purchase order. Owners of early model Contenders which have been converted to 'Easy Open' design should order those parts designated with an asterisk. **17**

# BARREL & FOREND PARTS LIST

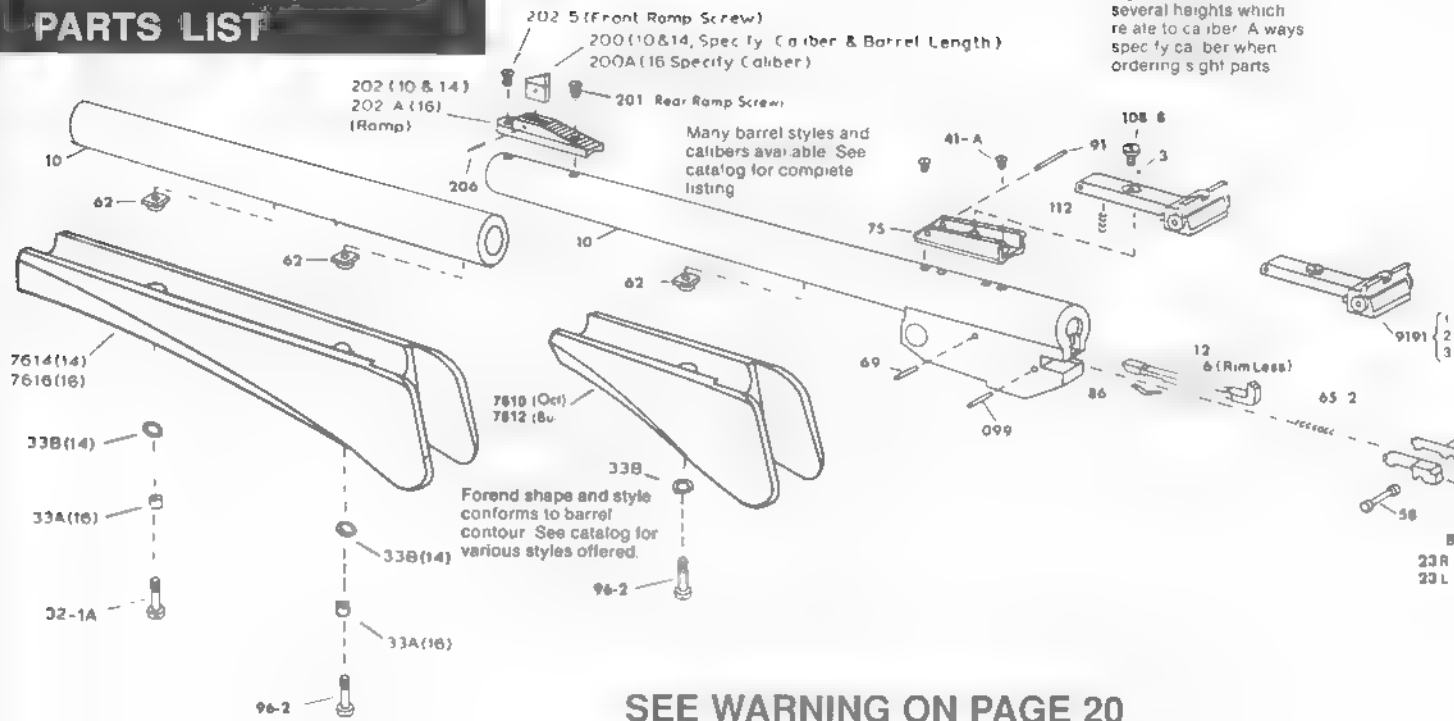

Standard front and rear sights are available in several heights which relate to caliber. Always specify caliber when ordering sight parts.

SEE WARNING ON PAGE 20

# RECEIVER & TRIGGER PARTS LIST

SEE WARNING ON PAGE 20

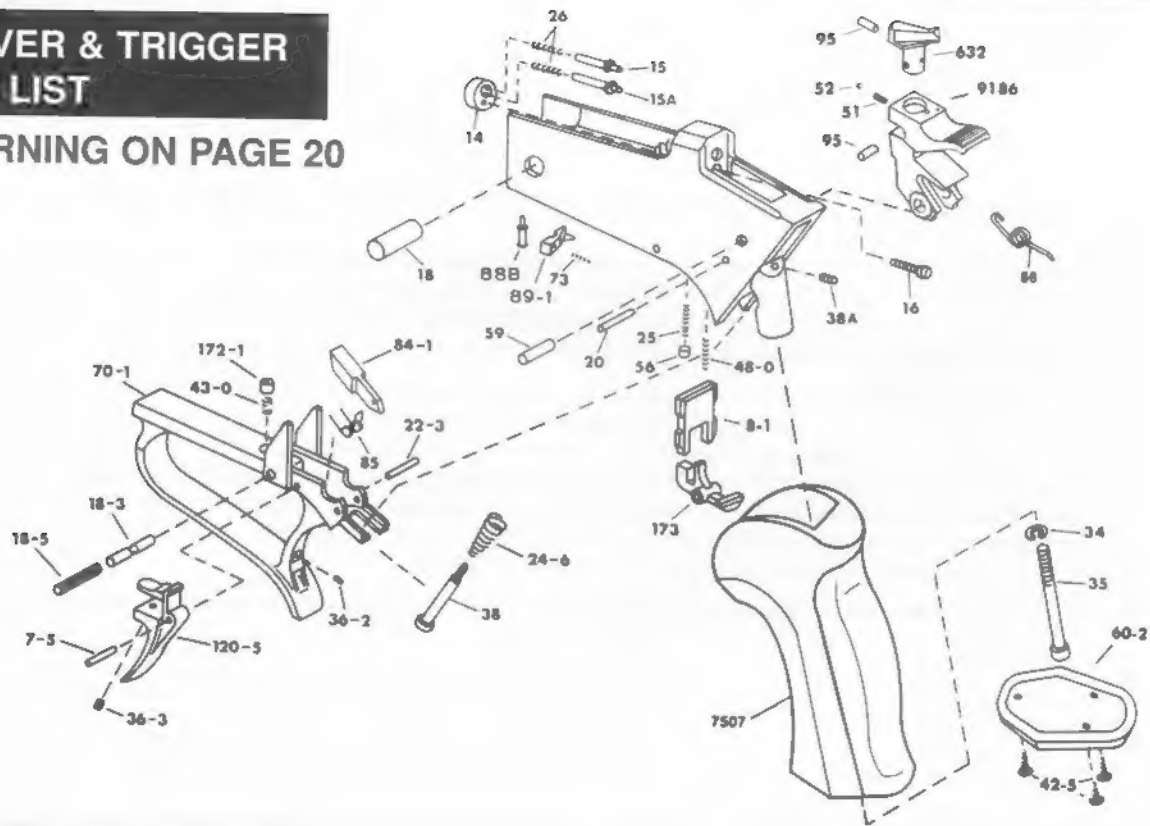

## —WARNING TO THOSE WHO PURCHASE PARTS—

Thompson/Center Arms is not responsible for repair of Contender Pistols unless the work is done by our factory service department (see page 14). There is no other way to ensure that the work will be done by a competent staff or trained technicians. We strongly recommend that Contenders needing repair be returned to the factory.

Consumers, dealers or gunsmiths who order individual parts must accept the responsibility for the correctness of the part itself. Equally, it is the installers responsibility to ensure that each part is properly fitted and functioning as an intricate part of the overall mechanism. **Improperly fitted parts can result in a dangerous malfunction, damaging the firearm and causing injury to the shooter and/or bystanders.** The purchaser and installer must accept full responsibility for the correct adjustment and proper overall functioning of the entire mechanism after such installation of parts.

**WARNING**

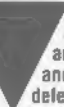

Discharging firearms in poorly ventilated areas, cleaning firearms or handling ammunition may result in exposure to lead and other substances known to cause birth defects, reproductive harm and other serious physical injury. Have adequate ventilation at all times. Wash hands thoroughly after exposure.

